



FMC125

Professional 4G LTE Cat 1 tracker with RS232, RS485 interfaces



FUTURE-PROOF NETWORK SUPPORT

Reliable 4G LTE Cat 1 network coverage with fallback to 2G – guaranteed future-proof network support for your fleet

FUEL MONITORING AND MORE

RS232/RS485 serial interfaces for fuel monitoring and other external data reading

SIGNIFICANTLY LOWER ROAMING COSTS

Dual SIM considerably reduces roaming costs

ACCURATE FUEL USAGE CONTROL

Impulse input for fuel flow meters data reading and accurate fuel usage control



Light vehicles



Heavy duty transport



Trailer Tracking



Refrigerated transport



International logistics



Car Sharing

FMC125 is small and professional real-time tracking terminal with GNSS and LTE/GSM connectivity and backup battery. Device equipped with GNSS/Bluetooth® and LTE modules, internal GNSS, LTE antennas. FMC125 features RS485/RS232 data interface, which gives ability to connect various third-party external devices. It is perfectly suitable for applications where location acquirement of remote objects is needed: fleet management, car rental companies, taxi companies, public transport, logistics companies, personal cars and so on.

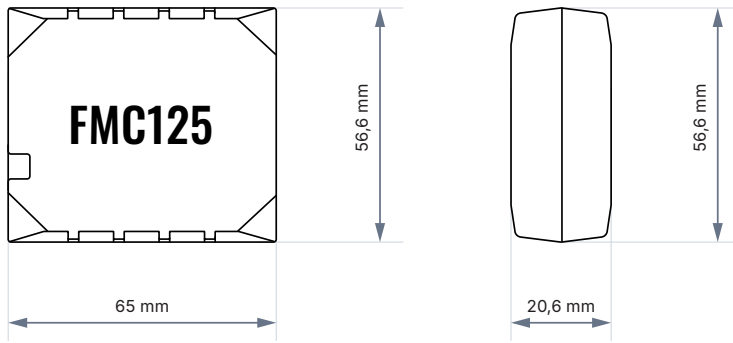

Module

Name	FMC125-MBIB0: MeiG SLM320-E with Teltonika TM2500 FMC125-MCIB0: MeiG SLM320-LA with Teltonika TM2500
Technology	LTE(Cat1)/2G(GSM/GPRS)/GNSS/BLUETOOTH® LE

GNSS

GNSS	GPS, GLONASS, GALILEO, BEIDOU, QZSS, AGPS
Receiver	Tracking: 33
Tracking sensitivity	-165 dBm
Position accuracy	< 2.5 CEP
Velocity accuracy	< 0.1m/s (within +/- 15% error)
Hot start	< 1 s
Warm start	< 25 s
Cold start	< 35 s

Cellular

Technology	LTE Cat 1, GSM
2G bands	FMC125-MBIB0: GSM: B2/B3/B5/B8 FMC125-MCIB0: GSM: B2/B3/B5/B8
4G bands	FMC125-MBIB0: LTE FDD: B1/B3/B7/B8/B20/B28 LTE-TDD:B38/B40/B41 FMC125-MCIB0: LTE FDD: B1/B2/B3/B4/B5/B7/B8/B20/B28 LTE-TDD:B40
Data transfer	LTE: LTE FDD: Max 10Mbps (DL)/Max 5Mbps (UL) LTE TDD: Max 8Mbps (DL)/Max 2Mbps (UL) GSM: GPRS: Max 85.6Kbps (DL)/Max 85.6Kbps (UL)
Data support	SMS (text/data)

Power

Input voltage range	10 - 30 V DC with overvoltage protection
Internal Back-up battery	170 mAh Li-Ion battery 3.7 V (0.63 Wh)

Power Consumption

Ultra Deep Sleep	At 12V < 4mA
Deep Sleep	At 12V < 6mA
Online Deep Sleep	At 12V < 12mA
GPS Sleep	At 12V < 19mA
Nominal (with no load)	At 12V < 36mA
with full Load / Peak	At 12V < 1A Max.

BLUETOOTH® technology

Specification	4.0 + LE
Supported peripherals	Temperature and Humidity sensor, OBDII dongle, Inateck Barcode Scanner, Universal Bluetooth® LE sensors support

Physical specification

Dimensions	65 × 56.6 × 20.6 mm (L x W x H)
Weight	55 g

Operating environment

Operating temperature (without battery)	-20 °C to +85 °C
Storage temperature (without battery)	-20 °C to +85 °C
Operating temperature (with battery)	-20 °C to +40 °C
Storage temperature (with battery)	-20 °C to +40 °C
Operating humidity	5% to 95% non-condensing
Ingress Protection Rating	IP41
Battery charge temperature	0 °C to +45 °C
Battery discharge temperature	-20 °C to +60 °C
Battery storage temperature	-20 °C to +45 °C for 1 month -20 °C to +35 °C for 6 months

Interface

Digital Inputs	2
Digital Outputs	1
Analog Inputs	1
CAN Adapter Inputs	1
1-Wire	1
RS232	1
RS485	1

GNSS antenna	Internal High Gain
Cellular antenna	Internal High Gain
USB	2.0 Micro-USB
LED indication	2 status LED lights
SIM	2x SIM Card (Dual-SIM)
Memory	128MB internal flash memory

Features

Sensors	Accelerometer
Scenarios	Green Driving, Over Speeding detection, GNSS Fuel Counter, DOUT Control Via Call, Excessive Idling detection, Immobilizer, iButton Read Notification, Unplug detection, Towing detection, Crash detection, Auto Geofence, Manual Geofence, Trip, Jamming detection*
Sleep modes	GPS Sleep, Online Deep Sleep, Deep Sleep, Ultra Deep Sleep
Configuration and firmware update	FOTA Web, FOTA, Teltonika Configurator (USB, Bluetooth® wireless technology), FMBT mobile application (Configuration)
SMS	Configuration, Events, DOUT control, Debug
GPRS commands	Configuration, DOUT control, Debug
Time Synchronization	GNSS, NITZ, NTP
Fuel monitoring	LLS (Analog), Digital LLS (RS232, RS485), LV-CAN200, ALL-CAN300, CAN-CONTROL, OBDII dongle
Ignition detection	Digital Input 1, Accelerometer, External Power Voltage, Engine RPM (CAN Adapters, OBDII dongle)
RS232 Modes	Log Mode, NMEA, LLS, LCD, RFID HID/MF7, Garmin FMI, TCP ASCII/Binary
RS485 Modes	Log Mode, NMEA, LLS, TCP ASCII/Binary
RS485 input voltage range on A or B pin (common-mode voltage)	-7V to +12V
RS232 input voltage range (common-mode voltage)	+/-15V
RS232 input voltage range (maximum operational voltage)	+/-25V

Certification & Approvals

Regulatory**	CE-RED, E-mark, Anatel, RCM,CITC, JATE, TELEC, SIRIM QAS, TRC, TRA, SIRA, ICASA, NTC, NBTC
--------------	--

* Jamming detection supported with SLM320-E and SLM320-LA modules.

** In progress